

IPSO HW94/22X WASHER

WRAS APPROVED PRODUCT

Installation Specification - Dimensions shown in millimetres

I/HW94/22X/09/04

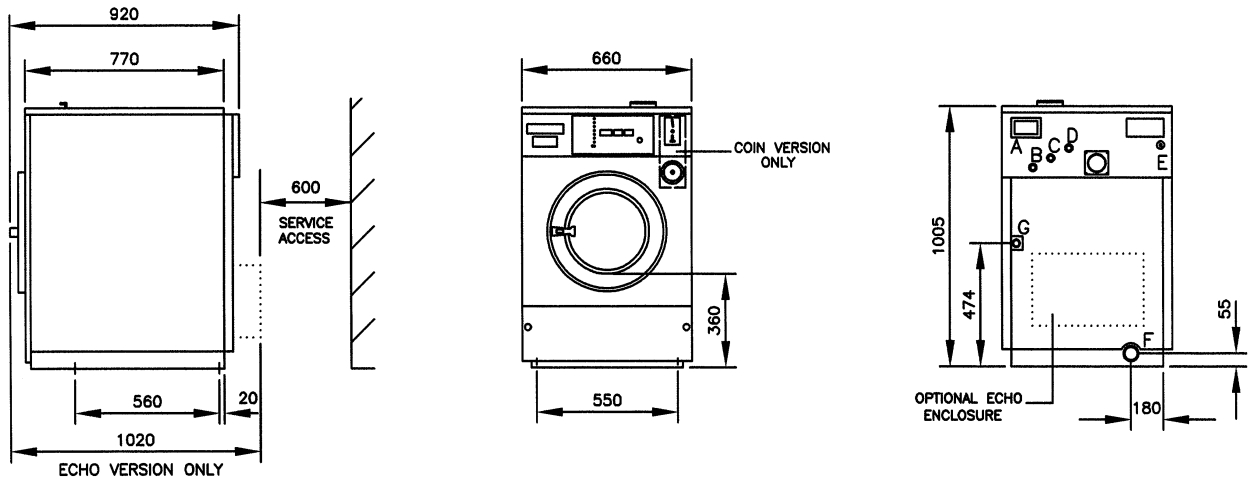

A - Ventilation Overflow Outlet, B - Soft Water Connection (cold), C - Warm Water Connection, D - Hard Water Connection (cold), E - Electrical Connection, F - Drain Outlet, G - Steam Connection

Model		HW94
Dimensions (HxWxD)		1005 x 660 x 920mm 1250 x 740 x 1000mm (Boxed)
Weight	Nett	208kg (458lb)
	Loaded	246kg (5426lb)
Dynamic bottom load		750N/16Hz
G-force	Low spin/High spin	74/296
Water		
No. of inlet valves		1 hot & 2 cold (hard & soft)
Recommended temperature (Hot water)		60°C
Minimum pressure		1.6 bar (25psi)
Inlet size		3/4" BSP
Flow rate		16 litres/min per supply
Average hot consumption		34.6 litres per cycle
Average total consumption		138.4 litres per cycle
Drain		
Size		50mm
Drain by gravity		80 litres/min
Electrical HW94 Manual		
Three phase	Self-heat 12kw	415v/50Hz/3ph + N/32A/ph
	Self-heat 9kw	415v/50Hz/3ph + N/20A/ph (Optional)
Single phase	Steam heat	240v/50Hz/1ph/10A (Optional)
	Boiler fed	240v/50Hz/1ph/10A (Optional)
	Self-heat 6Kw	240v/50Hz/1ph/32A (Optional)
	Self-heat 9Kw	240v/50Hz/1ph/45A (Optional)
22X coin Operated		
Single phase	Boiler fed	240v/50Hz/1ph/10A
Motor rating		750watt
Steam		
Consumption		9.5Kg/cycle (21lb/cycle)
Pressure		90 - 110psi
Connection		3/8" BSP
Minimum Installation Distance- Rear		600mm - read fixings on reverse

Foundations

The machine requires a foundation of solid and level concrete construction at least 200mm deep. If a new concrete pad is to be laid it must be keyed correctly into the existing foundations. The concrete foundation should always be greater in size than the machine and a minimum of 100mm from the edge of the concrete foundation to the edge of the machine must be provided. It is recommended that a metal raising plinth is used in conjunction with the concrete foundation. This will make the installation considerably easier, simplify for future servicing and raise the machine above the drain level for a correct evacuation of water from the machine. If block and beam or any type of floor with a void underneath is present, seek advice.

Fixings

A minimum service distance of 600mm is to be provided behind the machine (400mm if metal raising plinth is to be used). The machine needs to be securely fixed to the floor by 4 x M12 x 75mm fixing bolts. The type and specification of bolts will be determined by the quality and type of floor construction. The following types are generally accepted: rawlbolt, resin bonded fixings (chemfix) and Thru' bolts.

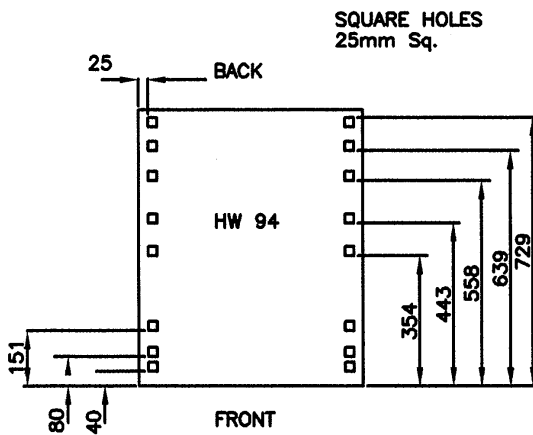

Water Supply

The machine is supplied with three water inlet valves, hot, cold hard and cold soft. If there is no soft water available or it is not needed, the soft and hard connections must come from the same supply. (Do not use plastic 'Y' pieces). The machine is fitted with its own Type 'A' Air Break System. This means that it can be connected directly to the mains supply. Separate 15mm hot and cold supplies are required. If more than one machine is to be installed, then the pipe sizes should be increased accordingly. These supplies should terminate in 3/4" BSP shut off valves with male threaded ends. If the hot water supply is insufficient in temperature, pressure or flow, the machine can then be connected solely to a cold water supply. This can only be done if the machine is equipped with a heating source, i.e. electric elements or a steam supply. This can however increase cycle times and running costs.

A minimum supply pressure of 25psi is required for each supply. If this is not available cycle times will increase. To overcome this a booster pump can be fitted: **PLEASE SEE SPECIFICATION FOR FLOW RATE REQUIRED.** The hot and cold supplies should be equal to within 25psi of each other. In hard water areas its recommended that the water supply is fitted with a water softner. Failure to do so will result in a detrimental effect on some component parts and may effect the standard warranty.

NOTE! ALL INSTALLATIONS MUST COMPLY WITH THE NATIONAL WATER REGULATIONS.

Drainage

The machine is fitted with a gravity drain outlet and must be positioned higher than the main drain. The drain outlet must be fitted with a "trap" removable for cleaning purposes. This is to ensure against odour re-circulation. To meet Health and Safety guidelines the drain must be sealed inside the building. Where a foul water supply discharges to an outside foul drain or gully, there is no requirement to seal the system, as it must be ventilated and accessible for cleaning. The underlying trap will prevent foul air from rising from the sewer. External gullies may be so placed for the displacement of surface or rainwater. The only exception to this rule is where the foul water discharge from the machines is under high pressure, thus rendering the water seal within the gully ineffective.

Electrical

Each machine must be individually protected. The isolation point for the machine should be in a readily accessible position for use in an emergency. All cabling to the machine shall be sufficiently protected against damage. It shall be correctly sized to the current rating of the machine. It should be connected to the machine using a suitable cable entry fixing. The commissioning engineer will carry out the final connection inside the machine. Circuit breakers or fuses should be used to protect the power supply. If fuses are used then they must be of the motor rated variety. A responsible and competent operative should carry out all electrical work and ensure that all local and national regulations and codes of practice are complied with.

Steam (Optional)

The machine should be connected to suitably sized live steam supply utilising an isolating valve, strainer/trap, electric solenoid inlet valve and a flexible steam connection hose. (Please note none of these fittings are supplied with the machine). All pipes should be lagged to protect against personal injury. All steam supply pipes should be installed to local and national codes of practice as they form part of a pressurised system.

NOTES:-

- 1 WHERE EXISTING SERVICES ARE TO BE CONNECTED TOO, THE INSTALLER MUST ENSURE THAT THESE ARE ADEQUATELY SIZED AND THAT THEY ARE IN GOOD WORKING ORDER. FOR EXAMPLE, IF A WASHER IS TO BE CONNECTED TO AN EXISTING DRAIN IT MUST BE CHECKED FOR ANY BLOCKAGES DURING INSTALLATION.**
- 2 FOR MULTIPLE MACHINE INSTALLATIONS SERVICES MUST BE INCREASED IN SIZE ACCORDINGLY. I.E WATER PIPES, DRAINAGE PIPES, ELECTRIC CABLES ETC..**